

Flange Serrated Nut

Thread Type: UNC / BSW - Coarse

Thread Direction: Right Hand

Material: Stainless Steel

Class Grade: A4-70 G316

Corrosion Protection Level: Ultimate

Standard: DIN 6923

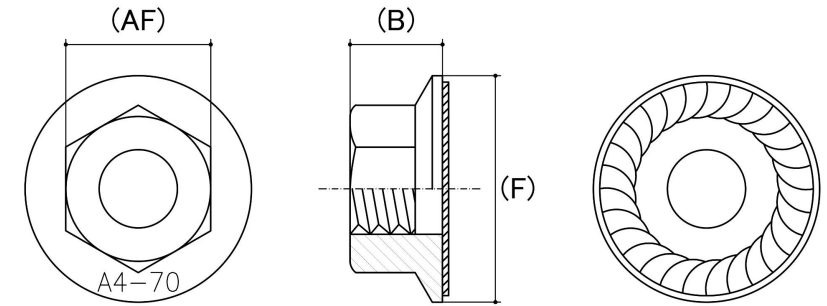

*CAD drawings shown for graphic representation only.**

Size	Thread Pitch (TPI)	Thread Type	Overall Nut Height (B) (mm)		Hex Height (H) (mm)	Flange Diameter (F) (mm)		Across Flats (AF) (mm)		Spanner Size (AF) (inches)	sku (qfind)
			Min	Max	Nom	Min	Max	Min	Max		
3/8"	16	Coarse	8.38	8.81	5.85	18.50	19.05	14.00	14.28	9/16	41FLSC38M

Disclaimer:

Dimensional data and technical information was obtained from publicly available sources and not acquired through standard agencies. It has been completed and compiled for reference purposes only; where discrepancies are found they are subject to change without notice. Bolt & Nut Australia makes no warranties or representations regarding the accuracy and validity of the compiled information and data. Contact the relevant standard authorities for accurate and detailed information.

* CAD drawings may not reflect diameter, thread length or overall length.

© Bolt & Nut Australia Pty Ltd. All rights reserved.

Version: 18 Mar 2024